



BP4078

400W switching audio power amplifier

Description

coldamp BP4078 is a 400W rms (4 Ω) full-range switching audio amplifier module, designed to fit into any audio amplification system, featuring low distortion and high S/N ratio.

Its small size allows to be used in small enclosures (including 1U 19" racks), powered speakers, subwoofers or car audio systems.

The design is based on **Class-D** concept, with synchronous natural-sampling PWM design. Its high efficiency (>90%) allows almost no-heat-sink operation and less wasted power, hence reducing power supply requirements.



Features

High-end performance:

- **400W** into 4 Ω , **240W** into 8 Ω , 2 Ω capability
- Gain: 34 dB (40 dB with balanced input), freq. response: 6 Hz to 50 KHz (-3dB)
- THD: 0.015% at 1W (5 Ω , 100Hz). < 0.5% at rated power.
- Global feedback system for reduced THD and almost load-independent frequency response.
- Almost silent turn on / turn off.
- Fully synchronous PWM design with clock input/output possibility that eliminates potential interchannel interferences produced in other free oscillating designs.
- RF post filter for best EMI behaviour

Easy and flexible connection:

- Simple supply requirements: symmetric +/-35 to +/-65V, with fast-on type connectors. However, connections for optional external +/- 8 to 15V (typ) and 12V driver supplies are provided for maximum efficiency even at low power.
- Balanced audio input, also featuring potentiometer header for easy volume control connection
- External TTL compatible on/shutdown input
- Integrated temperature sensor with header for flexible external thermal management
- Two modules can be bridged for higher power output without external circuitry

Onboard protections and indicators:

- Overcurrent protection (non dissipative), undervoltage lockout (UVLO) and Overvoltage shutdown (OV)
- All errors are latched for 2 secs, with output for LED indicator or external error management.
- Clipping indicator LED output

Small size, low weight and easy cooling

- Dimensions: 71x95x38mm – Fits into 1U standard 19" rack enclosures
- Weight: 186 g
- Screwing the module to a chassis or aluminium plate provides enough cooling for most applications.

Absolute maximum ratings

Parameter	Min	Typ	Max	Units
Supply voltage (+VCC and -VSS), to GND ⁽¹⁾	35	-	65	V
Modulator optional supply voltage (+ and -)	8	-	25	V
Mosfet Driver optional supply voltage (referred to -VSS)	15	-	25	V
Output current (peak) ⁽²⁾		18		A
ON!/OFF pin voltage	0	-	12	V
Minimum load impedance		2		Ω
Operating temperature (measured at onboard NTC)	-	-	80	$^{\circ}\text{C}$

Audio performance (V_{cc} , V_{ss} = +/-60v unless otherwise stated)

Parameter	Typ. Value	Units	Conditions
Output power, 4 ohms	400	W rms	0.5% THD, 1KHz sine, 4 ohms
Output power, 8 ohms	240	W rms	0.5% THD, 1KHz sine, 8 ohms
THD (Total Harmonic Distortion)	0.02	%	100Hz, 5 Ω , 1W, 10000uF/rail
SNR (Signal to noise Ratio)	>100	dB	Inputs shorted to GND
Bandwidth at -3dB	6-50K	Hz	8 Ω load
Bandwidth at -1dB	17-20K	Hz	8 Ω load
Input impedance	10	K Ω	
Output impedance ⁽³⁾	TBD		To be defined
Output ripple (at switching frequency)	500	mVpp	Inputs shorted to GND

Other parameters (V_{cc} , V_{ss} = +/-60v unless otherwise stated)

Parameter	Typ. Value	Units	Comments
Switching frequency	270	KHz	
ON!/OFF threshold voltage	2.5	V	Module is deactivated below that
Efficiency (output stage)		%	400W output at 4 ohms
Standby power (shutdown mode)	6	W	Measured with no input
Current consumption from +Vcc at idle	40	mA	Measured with no input
Current consumption from -Vss at idle	70	mA	Measured with no input
Clipping LED output current	8	mA	
Current drawn from ext. mod. supply	+35/-20	mA	Positive/negative supplies
Current drawn from ext. driver supply	60	mA	
PROTECT mode activated output voltage	12	V	
CLK output amplitude	6	Vpp	Triangle wave

NOTES:

⁽¹⁾ Below +/-35V, UVLO is activated, above +/-68V, OVP is activated.

⁽²⁾ Limited by overcurrent protection, that once triggered remains activated por 2 seconds approx.

⁽³⁾ Output impedance is not deteriorated by current limiting circuitry, as it doesn't use a sense resistor.

Connection

Labels in **RED** represent connections required for basic operation (supplies, speaker and input). Labels in **GREEN** represent expansion connections (remote on/off control, volume potentiometer, temperature measuring, synchronization between several modules, clipping indicator and protect mode indicator).

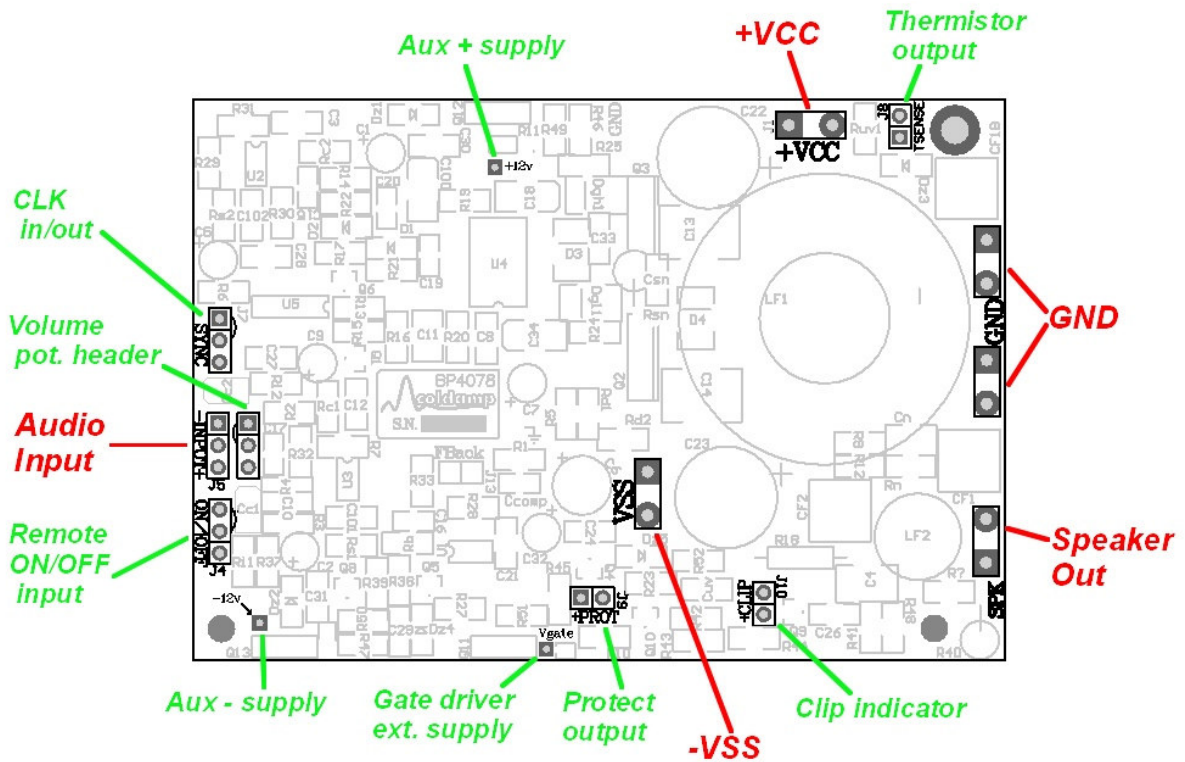

Fig 1: Connections of BP4078 module

Power supply:

The module only requires a symmetric (+ and – referred to GND) supply, ranging from +/-35V to +/-65V. Supplies under or above this will activate undervoltage lockout or overvoltage protection, respectively, preventing operation of the module.

The supplies can be easily obtained with only a center-tapped power transformer (use at least 350VA 42+42 VAC transformer for full power operation of one module), followed by a suitable full-wave bridge rectifier and filter caps (use at least 10.000uF per rail per module).

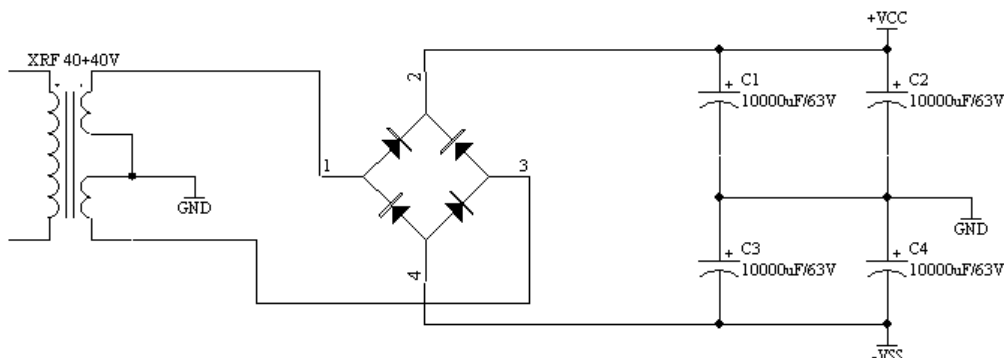

Fig.2: Example of linear power supply arrangement for the BP4078

Alternatively, a switching power supply from **coldamp** will be available soon. This supply allows drastic size reduction of the system, as the bulky toroidal mains transformer is no longer needed. This

allows the fitting of a complete amplifier in a single unit (1U) 19" case, for example, with only 44mm height.

It is very important to use thick and short wires to connect the +Vcc, -Vss and GND inputs to the power supply capacitors, as these wires carry heavy currents.

Speaker:

The module has speaker output and return fast-on connectors. Use thick and as short as possible wires here, preferably twisted together from the module to the speaker posts. For bridge mode connection, see "BP4078 Application Notes".

Input:

The module has differential inputs. This kind of connection (very rare in commercial equipment but extensively used in professional equipment), allows the connection of direct and out of phase input signals. If a regular (single ended) source, as a CD output, etc, is used, run the three wires (+, - and GND, assigned to pins 1, 2 and 3, respectively) to the input connector, then connect - and GND together at the input connector. This technique produces the cancellation of all the common mode noise picked up by the wires from the connector to the module input.

IMPORTANT: Use good quality microphone cable (shielded twisted pair, using the pair for +/- inputs and the shield for GND). Run the input wires as short as possible and away from the speaker and supply wires, as any noise produced by the high currents in them will interfere with the source signal, causing distortion. This is a common wiring recommendation for power amplifiers of any class.

Volume potentiometer:

For ease of connection, a single ended potentiometer header is provided after the balanced input preamplifier. This connection should be as short as possible to avoid noise pick-up. Pin 1 is GND, going to the lower potentiometer pin, pin 2 is potentiometer wiper and pin 3 is the upper potentiometer extreme.

IMPORTANT: If volume potentiometer is not connected (i.e, volume is controlled externally by the source), a jumper must be placed between pins 2 and 3 of that header.

ON/OFF control.

coldamp BP4078 module features an external shutdown control that allows disconnection of the module by an external switch for all modules in the system or a system controller that reacts to a remote control, switch, overtemperature controller, etc.

Connecting 5 to 10V to this input (or shorting pins 1-2) enables the amplifier (allow about 2 seconds for the onboard protection system to check for errors and softly start).

Connecting the input to GND (or shorting pins 2-3) puts the amplifier in shutdown mode, and assesing PROTECT output.

The on/off header provides the control input, +5V and GND, so the module can be switched on/off by a switch without the need of additional supplies or circuitry. Leaving the input open turns the module on.

Synchronisation input/output

Each **coldamp** module has an onboard clock oscillator that controls the modulator operation. Under certain circumstances, if several modules are put together in close proximity, the slight differences between each module frequency can lead to audible noises or "whistles". Unlike other modules,

BP4078 features a fully-synchronous design, so this can be corrected very easily by connecting one of the modules SYNC output to the SYNC inputs of the rest of them. Use a shielded cable as short as possible for this connection.

IMPORTANT: For normal operation, place a jumper between pins 1 and 2. Use normal operation (independent clocks) unless you experience whistles, as distortion may increase due to degradation of the clock along the connections, and supply transient requirements are more demanding.

Protection input/output

This signal provides a mean of knowing when the amplifier module is entering a “protect” or shutdown mode. This can be very useful to connect a LED diode that indicates the condition (**use a 2.2k resistor in series**), or to connect several modules together so when one of the modules enters protect mode, all the modules do the same. This is particularly useful when connecting modules in bridge mode: if for any reason one of the modules protects itself, there will be a large error signal in the speaker due to one of its leads being left floating by the inoperative module. Connecting the PROTECT signals together guarantees that both modules shut down at the same time.

Clipping indicator LED output

The module has an onboard clipping detection circuit that can activate an external LED (that can be connected directly, as a current limiting resistor is integrated in the board) whenever the output reaches a value within 2-3V to the supply voltage.

Note that the supply voltage is not the nominal voltage, but the real voltage fed to the amplifier, so when the supplies are low due to high load and/or not enough supply filter capacitance, real clipping is detected.

Clipping indicator feature is very useful for interactive adjustment of the input level by the user, and avoid amplifier saturation, that increases dissipation and can damage speakers.

Thermistor output

There is an onboard NTC (negative temperature coefficient) resistor mounted very near the output devices that has a resistance dependant on the temperature. Its leads are ruted to a header.

This provides a very convenient and easy way of measuring the temperature of operation of the amplifier, so a temperature management circuit can be easily connected if needed. Please refer to “BP4078 Application Notes” for more details about its response and use.

External auxiliary power supplies connection

For ease of connection, the BP4078 module includes onboard regulators for all internally required voltages, needing only the main supply (+/-35 to +/-65V) for full functionality. However, as the regulators are lineal, they produce some dissipation (around 6W at max. input voltage), heating up the chassis. Although this is not an issue as it is easily evacuated, if maximum efficiency is desired, there is also the possibility to add external low-voltage supplies for both the modulation and mosfet drive circuitry.

- The modulator needs +/-8VDC to +/-25VDC (clean and well bypassed) to operate correctly, rated at 45mA max. each.

- The driver needs +15VDC to +25VDC, **referenced to -VSS rail**, rated at 70mA max.

IMPORTANT: If external supplies are used, the three solder blobs near the transistors need to be removed (with a soldering iron) so the internal regulators remain disabled.

Cooling

coldamp high efficiency modules make cooling an easy task. The module case itself will be enough for mean power levels with low supply voltages, but to get the most from the amplifier, screwing it to a chassis will provide all the necessary heatsinking. The BP4078 module has 4 M3-threaded holes at the bottom that can be used to fix it to the chassis (see mechanical drawings at the end of this data-sheet). Ensure that both mating surfaces are very clean and use a small quantity of well spread thermal compound to improve thermal transfer.

Note that a small amount of heat is generated even when no signal is present if the internal regulators are enabled (default setup). So it is important that the case is well-ventilated by means, for example, of slits at the top, as in any other electronic equipment (any entirely closed chassis will heat-up with any small power loss to unacceptable temperatures, resulting in module failure).

Forced cooling will be only needed if the exterior temperature can be high or the case doesn't have enough ventilation. The thermistor output will prove very useful for controlling the optional fan or provide a means of thermal shutdown.

Chassis mechanical drawings

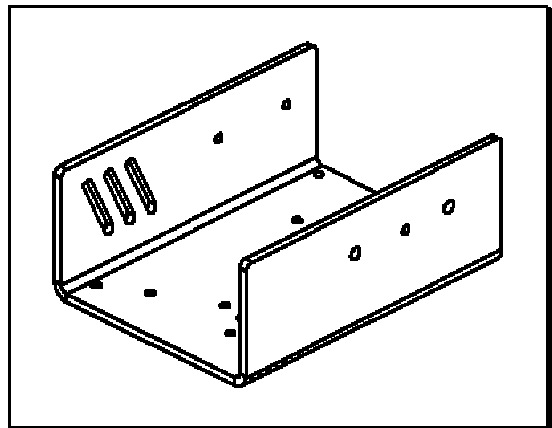
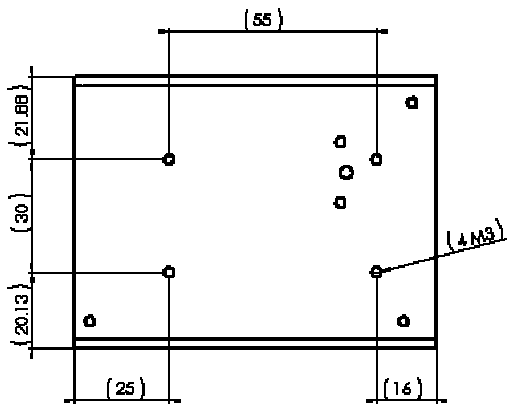
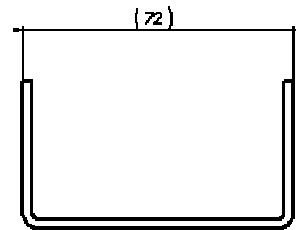
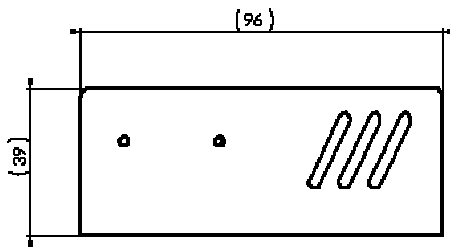

(All dimensions are in mm)

Important: Screws used to fix the module from the bottom plate must be M3 metric, max. 6mm plus the thickness of the mounting chassis.

Document History:

Revision E (30 November '05)

Module photo updated

Revision F (16 September '05)

Connections diagram updated

Revision E (5 September '05)

Added info about external auxiliary supplies

Revision D (29 August '05)

Cooling section text reviewed

Revision C (10 August '05)

Synchronisation section text reviewed

Revision B (23 June '05)

Mechanical drawings added