



The purpose of this document is to describe a basic connection setup example of the **coldamp BP4078** audio switching amplifier module. After that, some ideas for other advanced uses are detailed.

Topics covered in this document are:

1. *Basic set-up. Wiring and PSU recommendations.*
2. *Input signal connection options / volume control*
3. *Clipping indication*
4. *Protect / shutdown mode indication*
5. *Joining the Protect / shutdown signal of several modules*
6. *External on/stdby control*
7. *Bridging two modules for higher output power*
8. *Synchronization of several modules*
9. *Thermal management using onboard thermistor*
10. *Precautions using the modules.*

1. Basic setup. Wiring and power supply recommendations

In order to build a complete stereo 400+400W rms amplifier with linear power supply, few components are needed apart from two BP4078 modules and a suitable power supply:

- 2 **BP4078** modules
- 1 toroidal transformer. Minimum power should be 625VA, 40+40V AC
- 1 bridge rectifier (35A, for example) or 4 power diodes.
- Electrolytic filter capacitors (at least 63V rated). Minimum recommended capacitance is 10.000uF per rail for every channel.
- 2 fuses for the rails and 1 or 2 for AC mains.
- Thick wire (min. 1.5mm² section) for GND, +VCC, -VSS and SPEAKER connections.
- 2 audio input connectors, RCA for example.
- Speaker connectors, posts, etc.
- Some shielded audio wire.
- A suitable case
- IEC mains connector (for mains input) and power switch.

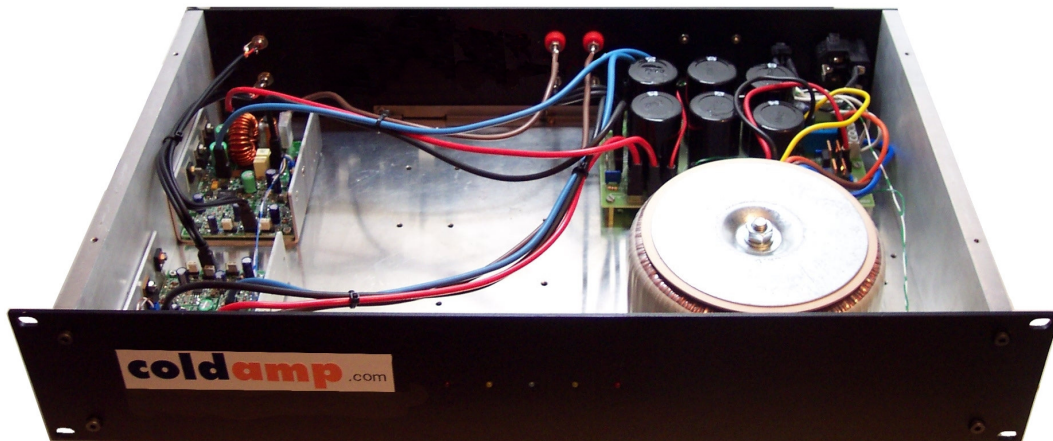

Fig.1: Example of basic 2ch. amplifier in a 19" 2U case

For basic connection of the modules, follow the datasheet connections guide, and have the following recommendations in mind:

- Wire the GND, +VCC and -VSS wires to each module directly from the power supply (not from the supply to one module and from there to the other one)
- Take the supply wires from the capacitors leads, not from the rectifier.
- Use a common ground point where all the GND wires connect tightly.
- Use thick wires for supplies and speaker and secure fastons very well.
- Speaker return should be wired from the power supply GND better than at the module speaker return faston. If possible, twist both + and - speaker wires together.
- Use as short as possible input cable, and as far as possible from mains, supplies and speaker wires. The same applies for the potentiometer connection (if used).
- The input cable should be shielded, and for better noise rejection, run the +, GND and - inputs to the input connector. If it is single-ended, connect the - wire to GND at the connector (not at the module input), as explained in section 2. This way, the common mode noise along the path is cancelled by the onboard balanced pre-amplifier.

PSU's soft start circuitry:

For high power and large filter capacitors, it is always recommended to build a soft-start or inrush limiting circuitry at the primary of the toroidal transformer, in order to limit the current drawn from the mains at start-up, due to the primary inductance of the transformer itself and the large current needed to charge the capacitors when they are totally discharged.

coldamp offers a complete linear power supply board that includes all the necessary circuitry to build a stereo amplifier, including bridge rectifier, filter capacitors, LED indicators for each rail, fuses and soft-start circuitry. Then only thing to add is the toroidal transformer.

Additionally, and to take the best advantage from BP4078 small size and weight, a **switching power supply** is also under development, with a size of approx. 20x12x38mm. This will permit the assembly of a complete 2 or 4 high power channels amplifier into a single unit 19" rack, for instance.

2. Input signal connection options / volume control

The BP4078 amplifier has an onboard balanced input stage, that is, it amplifies the difference between "+" and "-" inputs. Balanced outputs are present in professional equipment, and if they are available, connecting both inputs is the best option in order to obtain best noise performance. XLR or 6.3mm jack connectors are usually found in balanced equipment, like mixing-consoles, etc.

If a single-ended input is used (CD / DAT / MiniDisc / SACD player, cassette decks, PC soundcards, etc), it can be connected to the "+" input and GND, although it is good to have the three connections routed from the module to the input connector, and connect the "-" input to GND at that point, as shown before in fig. 2. This way, all the common mode noise picked up along that length is cancelled by the balanced amplifier.

In any case, always use good quality cable, preferably shielded twisted pair, using the internal pair for "+" and "-" signals, and the shield for GND. Microphone wire is very suitable for this purpose.

Fig.2: *Detail of connection of RCA single-ended inputs. Note that both signals (- and + and blue and red wires, respectively) are routed from the module, and - input is connected with GND **at** the connector. Both + and - signals are twisted inside the cable and shielded by the GND conductor. This is a common arrangement in microphone cables.*

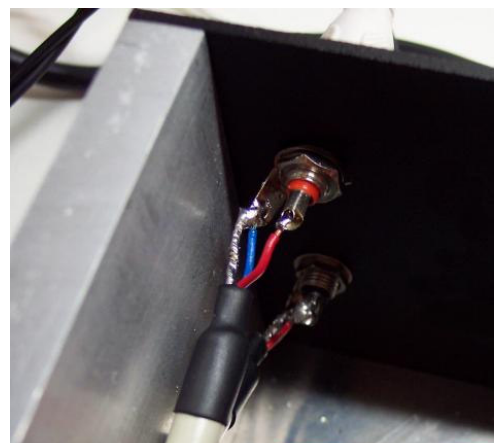

Volume potentiometer:

If the user wants a volume control in the system, additional circuitry would be needed if it had to be connected to the balanced input. However, the BP4078 eases this task by providing a potentiometer connector after the balanced amplifier, where the signal is single-

ended. This length of wire should be as short as possible, and if not used, a jumper must be placed between pins 1 and 2 in order to allow the signal to pass to the power stage.

3. Clipping Indicator

As with any other amplifier, clipping should be avoided in order to avoid excessive dissipation, very increased distortion and possible speaker damage.

Other modules leave the user the responsibility of providing an input which amplitude never allows going into clipping, and that's difficult in real-life operation, with a wide variety of inputs. Other solutions like compressors, limiters and/or autogain circuits distort the signal and make it sound unnatural or flat.

coldamp has decided to include a clipping detection circuit onboard, this way the user can know when the amplifier is reaching its voltage limit, so it can readjust the level to the more suitable value in every moment. The output of this circuit drives a LED directly so it can be conveniently wired and presented in the front of the equipment.

The clipping indicator activates whenever the output reaches the $-V_{ss}$ value within a safety band of around 3V.

4. Protect/shutdown mode indication

The module incorporates some security features in order to protect itself (and the speaker) against unexpected or inadequate conditions of operation. This conditions are:

- Overcurrent: whenever the instantaneous output current across the switches is greater than the trip point (15 amperes) due, for example, to an abnormally low impedance load or a shortcircuit at the output, the module is shut-down for about 2 seconds.
- Undervoltage: when the total supply voltage is below 64V, the module automatically shuts down in order to prevent erratical operation that could either produce annoying noises, or even damage the amplifier or the speaker. This is particularly important at turn off, when the rails voltage starts to decrease as the PSU capacitors get discharged. Once correct operation cannot be guaranteed, the module is automatically turned off quietly.
- Overvoltage: conversely, if the total supply voltage is higher than 135V, the amplifier could be in danger so it shuts down for min. 2 secs or the time this condition persists. This way, if an inadequate PSU is connected or capacitance is so low that pumping phenomena occurs, the amplifier remains safe.

Once any of these errors are detected, the PROTECT/SDN signal goes high (12V with respect to $-V_{ss}$ rail). This can be used to activate a LED (**with** a 1k5 resistor in series), or to synchronize the protection of several modules, as detailed in section 5.

NOTE: The PROTECT/SDN signal is also activated whenever the ON!/OFF control signal is low (shutdown mode).

5. Joining the Protect / shutdown signal of several modules

The PROTECT/SDN signal in the module can be used not only as an indication output, but also as a means of forcing all the modules connected in a system to shut down at the same time whenever any error condition is found in any of the amplifiers. This is particularly useful for **bridge** setups, where if for any reason one of the modules stops operation,

erroneous output will be sent to the speaker, so it is safer to turn both modules off at the same time.

In order to accomplish this functionality, all the PROTECT/SDN signals positive output (marked with a “+” on the corresponding jumper), must be connected together. If an indication LED is needed, it should be connected from the joining point to -Vss (at one of the modules or at the power supply), with a 2.2k resistor in series.

Fig. 3 shows how to connect several PROTECT/SDN signals together and a LED for indication.

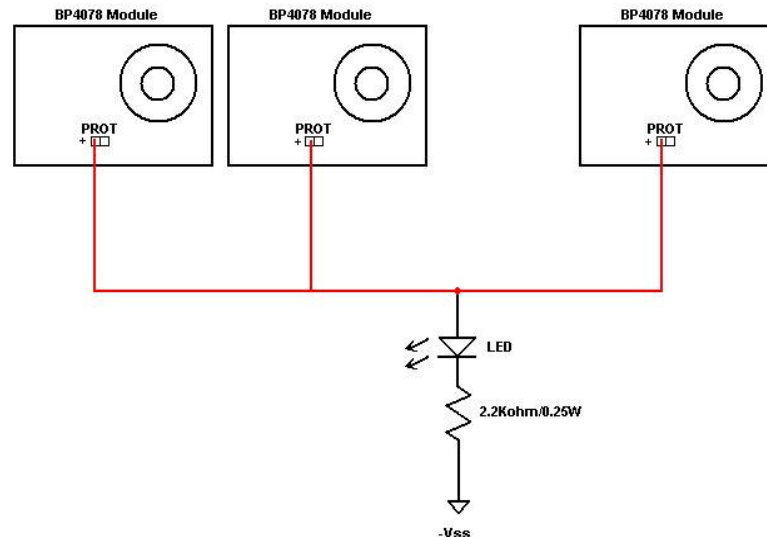

Fig. 3: Synchronisation of the PROTECT/SDN signals of several modules

6. External on/stdby control

For greater flexibility and power saving, the BP4078 module can be shut down remotely with a ground-referenced TTL and CMOS compatible signal, via the ON!/OFF connector. When in shutdown mode (ON!/OFF pin 2 < 5V), the power stage of the module stops operation and consumption is reduced from 10W to 5.5 W aprox. (with +/-60V supplies). The PROTECT/SDN LED is activated as well.

Once the module is re-activated by leaving it open, connecting it to **pin 3** or connecting a voltage higher than 5V, the module waits about 2 seconds in order to achieve silent turn-on.

7. Bridging two modules for higher output power

BP4078 design allows the connection of two equal modules in bridge-mode in order to increase output power.

Bridge mode requires the same input signal to both modules, but with a 180° phase shift. Due to the balanced nature of the BP4078 input, this can be readily accomplished with no additional components, only by connecting the signal source to the (+) input of one module and also to the (-) input of the other one. It is good to run the other input right to the connector and short it to GND in order to cancel common mode noise along the wires, just as with single-ended applications.

There are three important points that must be observed when using BP4078 modules in bridge mode:

7a: As with any amplifier wired in bridge mode, each channel sees half the impedance of the load. That means that the minimum recommended load useable in this mode is 8 ohms, or the overcurrent protection may trigger. The maximum power output at this load is around **800W**, depending on the power supply voltage and power rating.

7b: The **PROTECT** outputs of both modules should be joined together (see section 5), in order to avoid that one of the modules shuts off when the other one is already running, thus creating a large unbalance in the speaker.

7c: As seen by each amplifier, the load is floating, so for proper start-up of the modules it is required that a 560 ohm (maximum), 5W resistor is tied from each speaker output o GND. This guarantees proper operation in bridge mode.

8. Synchronisation of several modules

Under certain circumstances, if several modules are placed very near of each other, the small deviations from nominal clock frequency can lead to heterodyne interference causing an increased noise floor or even small high-pitched “whistles”. In that case, it is recommended to separate the modules until that effect disappears. As a last attempt, the modules can be synchronised together with the clock input/output connector. This can lead to a slight increase in the distortion level due to degradation of the clock along the connections.

9. Thermal management using onboard thermistor

There is an onboard NTC (negative temperature coefficient) resistor mounted close to the output devices, that shows a temperature dependent resistance. Its pins are ruted to a header.

This provides a very convenient and easy way of measuring the temperature of operation of the amplifier, so a temperature management circuit can be easily connected if needed.

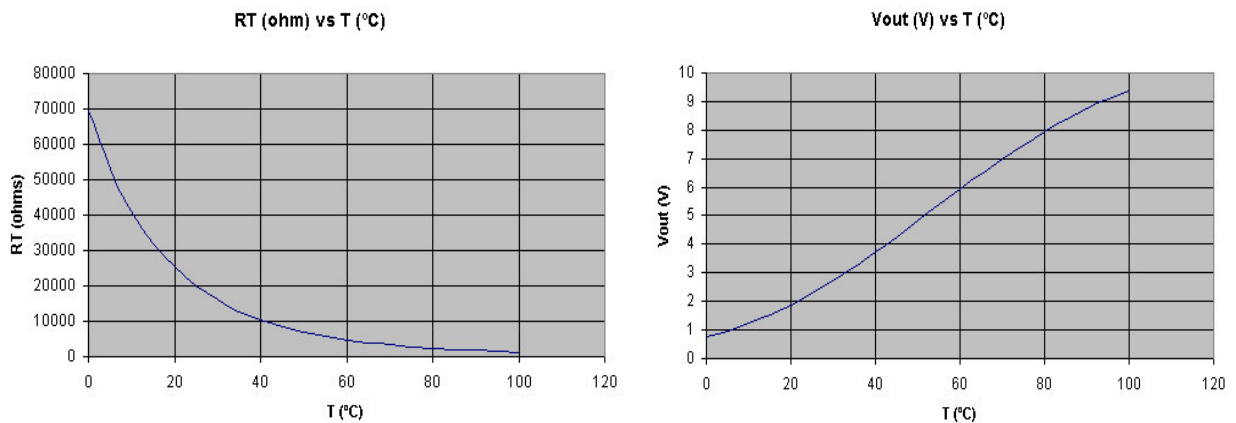
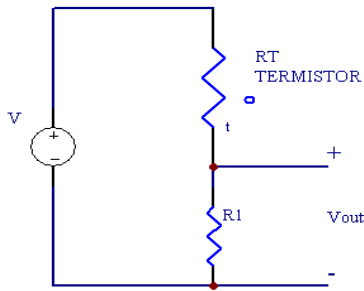

Fig 4: (left) R/T curve of the onboard thermistor. (right) Voltage when used in circuit shown at the bottom left figure, where R1=4.7KΩ, V=12V.



Connecting the NTC with another fixed resistor in series as shown at the left, is an easy way to have a temperature-dependant voltage output. Fig 4b plots the voltage obtained by using a 12V source and a 4.7K Ω resistor to GND (that forms a divider together with the thermistor). This voltage can be fed to a comparator, etc to activate the shutdown pin, a fan or the desired protection system.

For example, fig.5 shows a simple circuit that connects to the 2-pin thermistor header in the board and activates its output when the temperature reaches aprox. $T_{on}=54^{\circ}C$, while it is turned off only when it has decreased to about $T_{off}=48^{\circ}C$. This output can be connected (once inverted) to the module(s) control input to turn it off, or can activate a fan by means of a medium power transistor or mosfet.

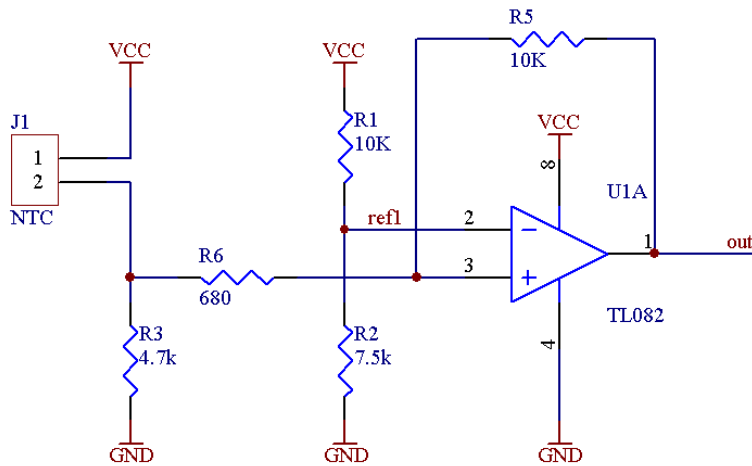

Fig. 5: Example of temperature control circuit using onboard NTC

The trigger temperature and hysteresis margin can be adjusted via $R1/R2$ and $R6$. In fact, $R1$ and $R2$ can be implemented with a 20k Ω potentiometer and $R6$ can be a 2k Ω potentiometer itself. The adjustment procedure can be the following:

Make $R6=0\Omega$, so there is no hysteresis, and apply a increasing voltage to the circuit input until it triggers (out=12v aprox). That will correspond to the midpoint between the T_{on} and T_{off} temperatures. Now increase $R6$ to create a hysteresys band around that point.

The opamp can be almost any model that is at hand, and the recommended supply is 12Vdc.

A simple HCMOS logic gate (such as 4011), or a NPN transistor can be used to invert the logic level and attack the BP4078 control input directly so the module is shut-down when the temperature hits T_{on} and is only released when it has gone down to T_{off} ($T_{on}>T_{off}$).

Document History:

Revision D (3 September '05)

*Bridge mode operation information added.
Change from "preliminary" to "release" status.*

Revision C (22 August '05)

Connection of PROTECT signals completed

Revision B (10 August '05)

Synchronisation text reviewed

Revision A (20 June '05)